**Inductive Shaft encoder, Absolute**

- 58mm diameter
- Extremely robust design
- Shock and vibration protected
- Inductive scanning
- Stainless steel EN 1.4404/AISI 316L

**Encoder configuration**

Type	ISA
Model	638 Multiturn stainless steel
Shaft type	Ø10 mm round
Flange type	Clamping flange (61sp-type)
Power supply	9-36 Vdc
Output interface	PROFIBUS DP
Absolute resolution	25 bit (13 bit singleturn + 12 bit multiturn)
Connection type	Cable gland
Connecting direction	Radial

Mechanical data

Operating temperature	-40 °C...+70 °C
Ingress protection class [IEC 60529]	IP67
Vibration [IEC 60068-2-6]	≤ 300 m/s ²
Shock [IEC 60068-2-27]	≤ 2000 m/s ²
Shaft load (axial/radial)	100 / 125 N
Rotational speed max	12000 rpm
Shaft material	Stainless steel (A4, AISI 316L, EN 1.4404)
Cover material	Stainless steel (A4, AISI 316L, EN 1.4404)
Weight	750 g

Electrical data

Polarity protected	Yes
Current consumption	95 mA at 24 Vdc
Absolute accuracy	± 180 arcsec
Supported profile	Encoder profile 3.062 and 3.162 v4.1
Node adress	Settable via DIP switches, 0...99
Baud rate	Max. 12 Mbit/s

Dimensions

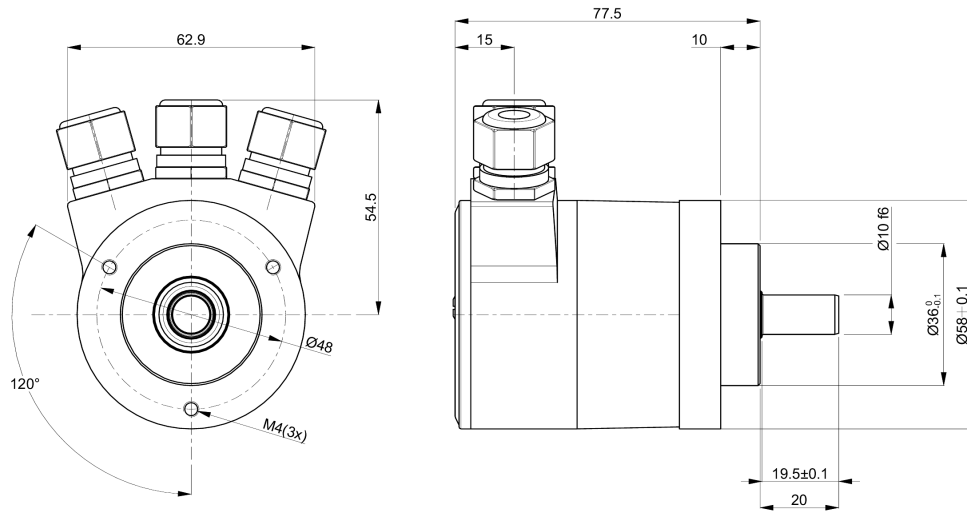

Supported functions

Preset, Scaling, Code sequence, Isosynchronous mode (only DPV2), Velocity (only DPV0 class 2)

Pin Configuration

Function	Terminal
+E Volt	+ (1)
0 Volt	- (2)
B** (Bus in)	B (3)
A* (Bus in)	A (4)
B** (Bus out)	B (5)
A* (Bus out)	A (6)

*A terminals are connected

**B terminals are connected

Order information

Part number	827376-02
-------------	-----------