

51

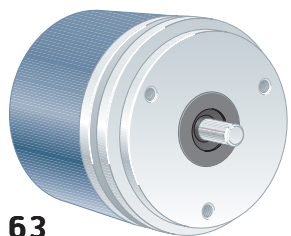

63

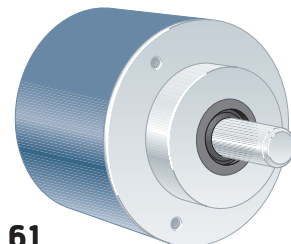

61

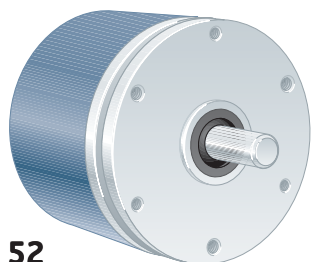

52

Short description:

- >> 13 bit CANopen output
- >> IP 67 at housing, IP 66 at shaft inlet
- >> 9...36 Vdc
- >> Robust housing for harsh environment
- >> Shock and vibration protected

Suitable applications:

- >> Standard to demanding industrial applications
- >> Positioning applications
- >> Printing machines
- >> Packaging machines

General information

Encoder data	
Type	RSA 507
Operating temperature	-40°C .. +80°C
Storage temperature	-30°C .. +80°C
Ingress protection class	IP-67 according to IEC 60529
At shaft inlet	IP-66 according to IEC 60529
Vibration (55 to 2000Hz)	< 300 m/s ² according to IEC 60068-2-6 ⁽¹⁾
Shock (6ms)	< 2000 m/s ² according to IEC 60068-2-27
Cover material	Aluminium
Cover surface treatment	Coated and cromated or anodized
Weight	Approx. 300g
Accuracy and resolution	
Resolution	13 Bit, 8192 positions per revolution (Scaleable)
Accuracy	± 1 LSB

Flange option

Flange type	51, LL58	63, Synchro	61, Clamping	52, LL68
Outer diameter	ø58 mm	ø58 mm	ø58 mm	ø68 mm
Mounting holes	3 x M3 & 3 x M4	3 x M4	3 x M3	3 x M3 & 3 x M4
Flange material	Aluminium	Aluminium	Aluminium	Aluminium
Surface treatment	Anodized	Anodized	Anodized	Anodized

Shaft option

Shaft type	Ø 6 round	Ø 6 with face	Ø 10 round	Ø 10 with face
Axial shaft load	50 N	50 N	50 N	50 N
Radial shaft load	60 N	60 N	60 N	60 N
Mech. permissible speed	6000 rpm (12 000)	6000 rpm (12 000)	6000 rpm (12 000)	6000 rpm (12 000)
Shaft material	Stainless steel	Stainless steel	Stainless steel	Stainless steel
Moment of inertia	1,9 x 10 ⁻⁶ kgm ²	1,9 x 10 ⁻⁶ kgm ²	2,0 x 10 ⁻⁶ kgm ²	2,0 x 10 ⁻⁶ kgm ²

⁽¹⁾<150m/s² on encoders with connectors



Connection option

Connector type	Cable	8 pin M12	12 pin EML	8 pin PT
Function	Colour	PIN	PIN	PIN
Adress Bit 0	White	1	1	A
Adress Bit 1	Brown	2	2	B
Adress Bit 2	Grey	3	3	C
Adress Bit 3	Pink	4	4	D
Adress 0V	Blue/Red	NA	11	NA
CAN_H	Green	5	8	G
CAN_L	Yellow	6	9	H
0V	Blue	7	10	F
+EV	Red	8	12	E
Housing	Shield	Chassis	Chassis	Chassis
Connecting direction (available on flange option -51, -63, -61)				
Axial	Yes	Yes	Yes	Yes
Radial	Yes	Yes	Yes	Yes
Connecting direction (available on flange option -52)				
Axial	No	No	No	Yes
Radial	Yes	No	No	No

NA=Not available

Electrical option

Power supply	9-36Vdc
Polarity protected	Yes
Output interface	CANopen
Short circuit protected	Yes
Current consumption	100mA @ 24Vdc
Max current consumpt.	150mA
Physical interface	CAN according to ISO-11898
Supported profile	Device profile for encoders DS406 v2.0
Baud rate ⁽¹⁾	Max. 1Mbit/s software adjustable
Node adress	Hardware or software adjustable
Code type	Binary
Supported functions	Code sequence, Preset, Scaling and Node Guarding
Position update freq.	1kHz
Start up delay	700ms

⁽¹⁾ Default baud rate 125 kBit/s

Accessories

Accessories	Part number
Configuration file EDS file	619208-01
Mating connector 8 pin M12 8 pin PT 12 pin EML	00201081 ⁽¹⁾
	00201009 ⁽¹⁾
	01209090 ⁽¹⁾
Coupling 6-6 mm 10-10 mm	464192222 ⁽²⁾
	464333232 ⁽²⁾
Mounting bracket	00208011 ⁽³⁾
Bearing box	01209010 ⁽⁴⁾

⁽¹⁾ Also available with assembled cable.

⁽²⁾ Other couplings are also available.

⁽³⁾ Only for 63 Synchro and 61 Clamping flanges.

⁽⁴⁾ Only for 63 Synchro flange.

For additional accessories like assembled cables, mounting clamps, measuring wheels, draw wire box etc.

Please advise separate datasheets for accessories.



Dimensions

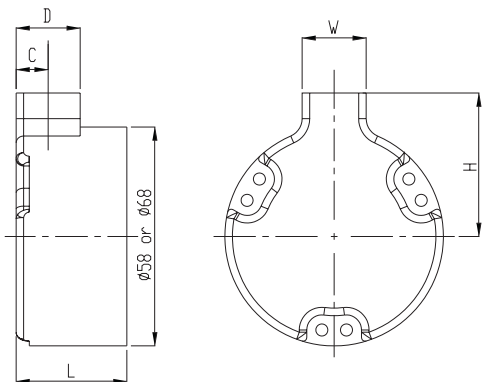

Connector	Orientation	L	H	W	D	C
Cable	Radial Ø58	29,4	34	17	17	8,5
	Radial Ø68	44,7	34	0	0	14
	Axial	38,9				
EML	Radial	29,4	32	27	27	13,5
	Axial	38,9				
8p M12	Radial	29,4	38	27	27	9,5
	Axial	38,9				
8p PT	Radial	29,4	41	27	27	13,5
	Axial Ø58	38,9				
	Axial Ø68	44,7				

Note: For complete encoder dimension please add connector and flange dimensions.

Flanges

51, LL58

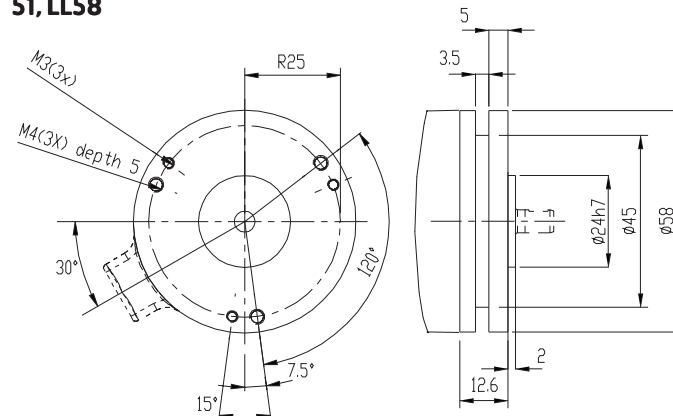

63, Synchro

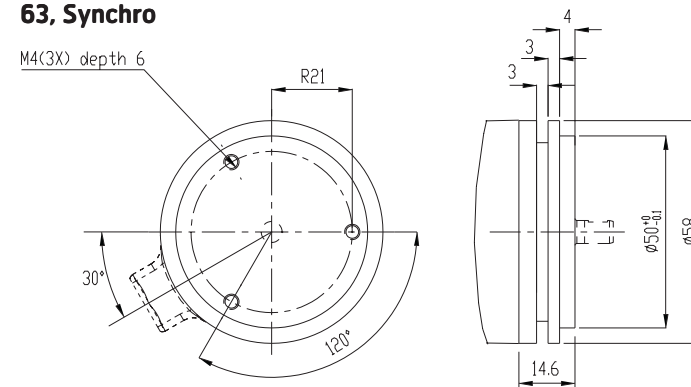

61, Clamping

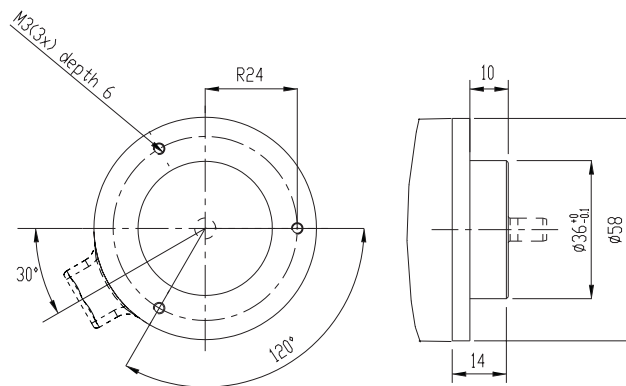

52, LL68

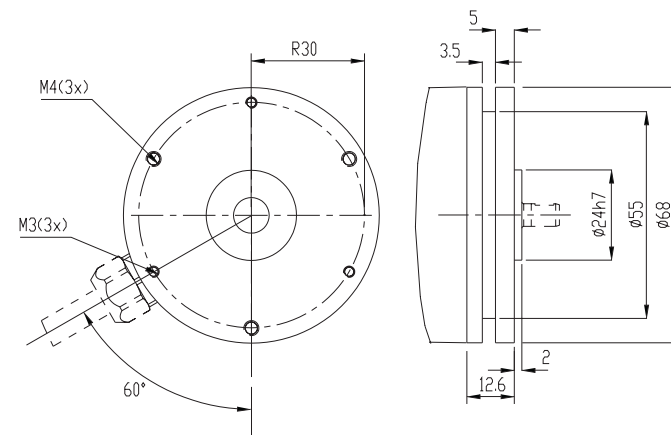



Connectors

Cable
12x0,25 shielded

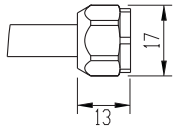

8pin M12

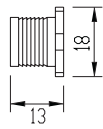

12pin EML

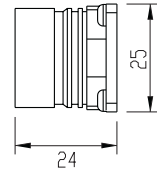

8pin PT

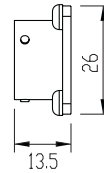

Shafts

6 mm with face

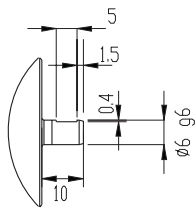

6 mm round

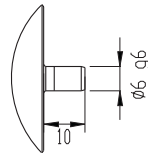

10 mm with face

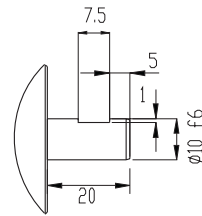

10 mm round

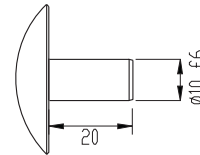

Various combinations/examples

RSA 507 51

10 mm with face, axial M12

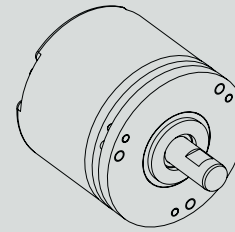

RSA 507 63

6 mm with face, radial PT

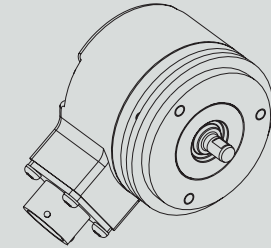

RSA 507 61

6 mm round, radial cable

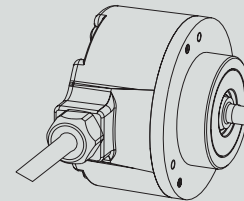

RSA 507 52

6 mm with face, axial M12

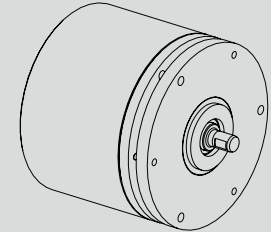

Ordering information Tick your choice

Type	RSA 507				
Flange	51, LL58	63, Synchro	61, Clamping	52, LL68	
Shaft	Ø6mm round	Ø6mm with face	Ø10mm round	Ø10mm with face	
Electronics	Supply	9-36Vdc			
	Output	SCO, CANopen			
Connection	Cable ⁽¹⁾	8 pin M12	12 pin EML	8 pin PT	
Connecting direction	Axial/Radial	Axial/Radial	Axial/Radial	Axial/Radial	
Resolution	13 bit				

⁽¹⁾ Note: Please specify cable length when ordering

Ordering example: RSA 507 63 Ø10r0 9-36Vdc SCO 12 pin EML Radial 13bit
Assembly drawing is available upon request from Leine & Linde AB