

51

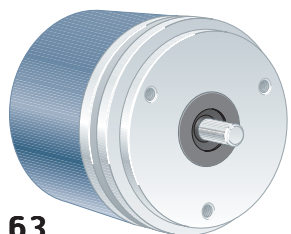

63

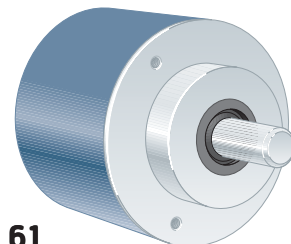

61

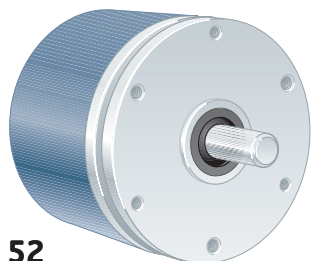

52

Short description:

- >> 6 short-circuit protected outputs
- >> IP 67 at housing, IP 66 at shaft inlet
- >> 5 Vdc or 9...30 Vdc
- >> Robust housing for harsh environment
- >> Shock and vibration protected

Suitable applications:

- >> Standard to demanding industrial applications

General information

Encoder data		
Type	RSI 503	
Operating temperature	-40°C .. +70°C	
Storage temperature	-30°C .. +70°C	
Ingress protection class	IP-67 according to IEC 60529	
At shaft inlet	IP-66 according to IEC 60529	
Vibration (55 to 2000Hz)	< 300 m/s ² according to IEC 60068-2-6 ⁽¹⁾	
Shock (6ms)	< 2000 m/s ² according to IEC 60068-2-27	
Cover material	Aluminium	
Cover surface treatment	Coated and cromated or anodized	
Weight	Approx. 300g	
Accuracy and resolution		
Line count	1..5000 ppr	5001..10 000 ppr
Dividing error	± 50 °el	± 90 °el
Channel separation	90 ± 25 °el	90 ± 45 °el
Measuring steps	4 x Line count	

Flange option

Flange type	51, LL58	63, Synchro	61, Clamping	52, LL68
Outer diameter	ø58 mm	ø58 mm	ø58 mm	ø68 mm
Mounting holes	3 x M3 & 3 x M4	3 x M4	3 x M3	3 x M3 & 3 x M4
Flange material	Aluminium	Aluminium	Aluminium	Aluminium
Surface treatment	Anodized	Anodized	Anodized	Anodized

Shaft option

Shaft type	Ø6 round	Ø6 with face	Ø10 round	Ø10 with face
Axial shaft load	50 N	50 N	50 N	50 N
Radial shaft load	60 N	60 N	60 N	60 N
Mech. permissible speed	6000 rpm (12 000)	6000 rpm (12 000)	6000 rpm (12 000)	6000 rpm (12 000)
Shaft material	Stainless steel	Stainless steel	Stainless steel	Stainless steel
Moment of inertia	1,9 x 10 ⁻⁶ kgm ²	1,9 x 10 ⁻⁶ kgm ²	2,0 x 10 ⁻⁶ kgm ²	2,0 x 10 ⁻⁶ kgm ²

⁽¹⁾<150m/s² on encoders with connectors

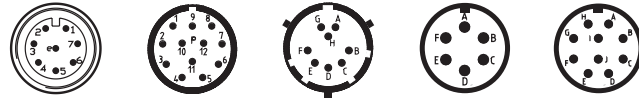

Connection option

Connector type	Cable	8 pin M12	12 pin EML	8 pin PT	6 pin MS	10 pin MS
Function	Colour	PIN	PIN	PIN	PIN	PIN
S00	Yellow	4	5	D	D	D
S00 inverted	Black	5	6	C	C	C
S90	Green	3	8	A	A	A
S90 inverted	White	1	1	B	B	B
Sref	Brown	2	3	G	NA	G
Sref inverted	Violet	6	4	H	NA	H
+E Volt	Red	8	12	E	E	E
0 Volt	Blue	7	10	F	F	F
STATUS	Grey	NA	7	NA	NA	I
Case	Shield	Chassis	Chassis	Chassis	Chassis	Chassis
Connecting direction (available on flange option -51, -63, -61)						
Axial	Yes	Yes	Yes	Yes	Yes	Yes
Radial	Yes	Yes	Yes	Yes	No	Yes
Connecting direction (available on flange option -52)						
Axial	No	No	No	Yes	No	Yes
Radial	Yes	No	No	No	No	No

Electrical option

Power supply	5 V ±10%	9-30 V	
Polarity protected	No	Yes	
Output signals	TTL ¹	HTL	RS-422
Short circuit protected	Yes	Yes	Yes
Current consumption	45 mA	50 mA at 24Vdc	25 mA at 24Vdc
Max consumption	75 mA	75 mA	40 mA
Output load (max)	±20 mA	±40 mA	±20 mA
Output frequency (max)	300 kHz	300 kHz	300 kHz
U _{high} at 10mA load	> 3.0 V	> +EV - 2.0 V	> 3.0 V
U _{low} at 10mA load	< 0.4 V	< 1.15 V	< 0.4 V
Cable length (max)	50 m	200 m @ 50 kHz	1 km (TIA/EIA-422-B)
STATUS output	Yes	Yes	Yes
High level	Encoder OK	Encoder OK	Encoder OK
Low level	Warning/Failure	Warning/Failure	Warning/Failure

¹TTL output comply to the RS-422 standard when differential transmission is used NA=Not Available

Output circuit

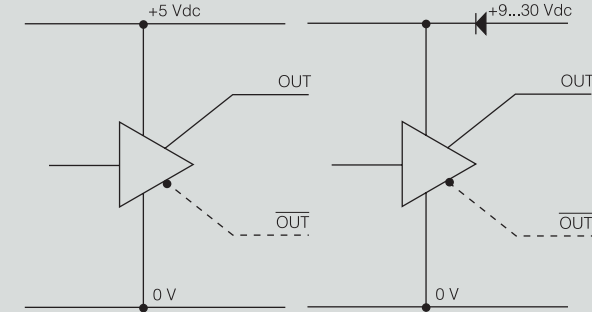

Output signals

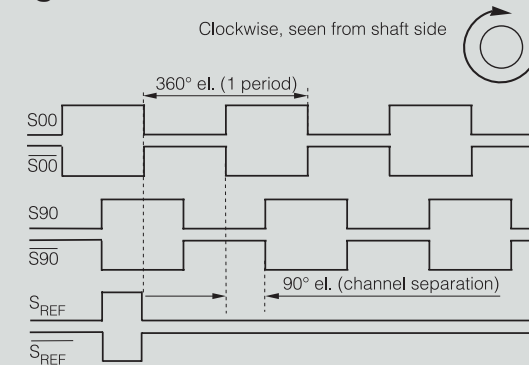

Status outputs

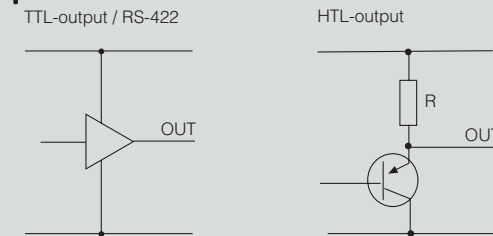

Dimensions

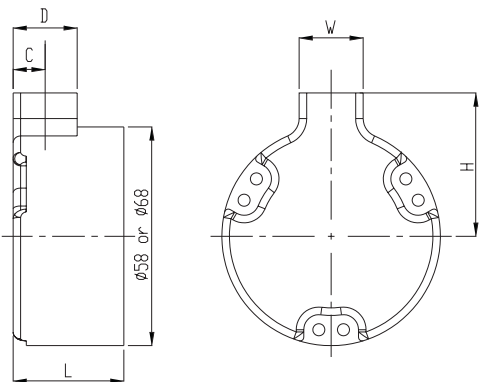

Connector	Orientation	L	H	W	D	C
Cable	Radial $\phi 58$	29.4	34	17	17	8.5
	Radial $\phi 68$	44.7	34	0	0	14
	Axial	38.9	-	-	-	-
EML	Radial	29.4	32	27	27	13.5
	Axial	38.9	-	-	-	-
PT 8p	Radial	29.4	41	27	27	13.5
	Axial $\phi 58$	38.9	-	-	-	-
	Axial $\phi 68$	44.7	-	-	-	-
MS 6p	Radial	-	-	-	-	-
	Axial	38.9	-	-	-	-
MS 10p	Radial	-	-	-	-	-
	Axial $\phi 58$	43.9	-	-	-	-
	Axial $\phi 68$	44.7	-	-	-	-
M12 8p	Radial	29.4	38	27	27	9.5
	Axial	38.9	-	-	-	-

Flanges

51, LL58

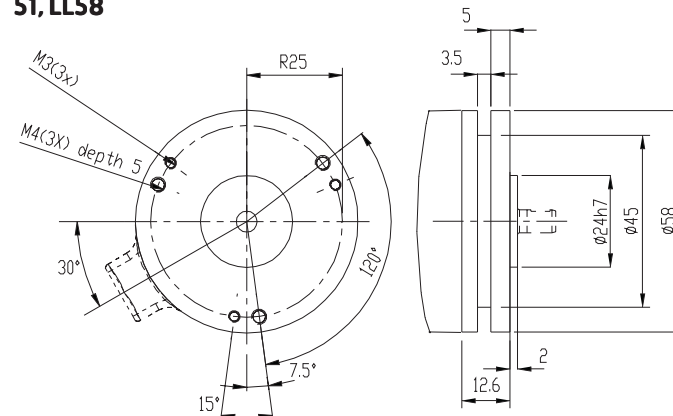

63, Synchro

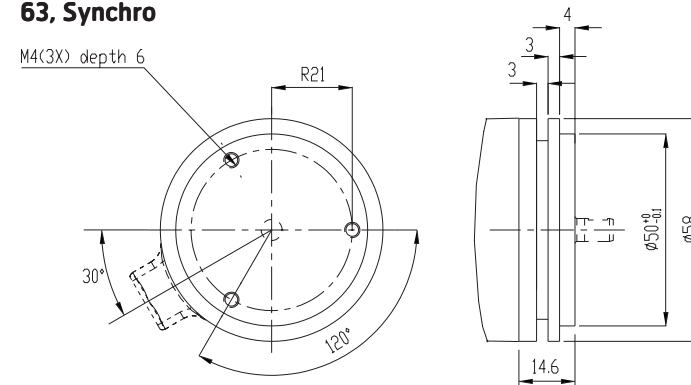

61, Clamping

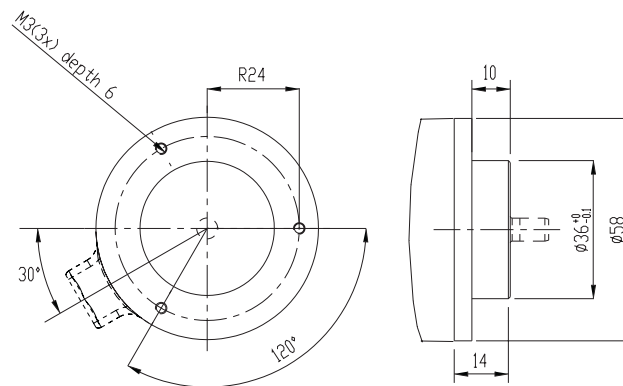

52, LL68

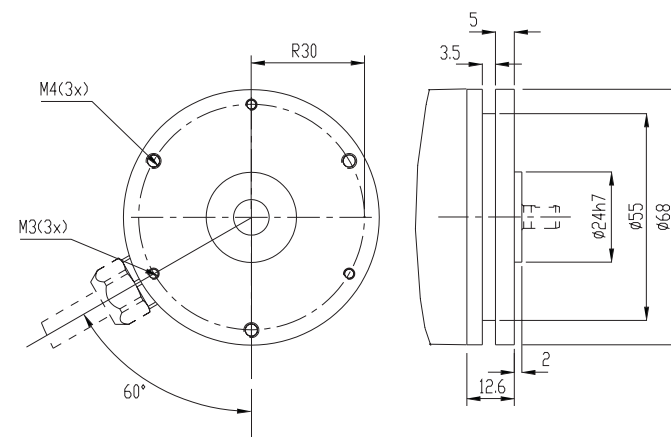

Connectors

Cable
5x2x0,25 shielded

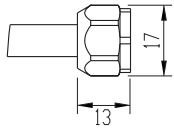

8pin M12

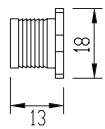

12pin EML

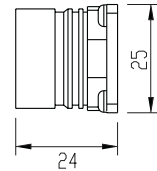

8pin PT

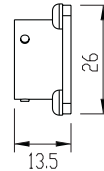

6pin MS

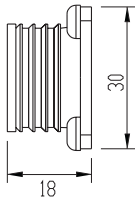

10pin MS

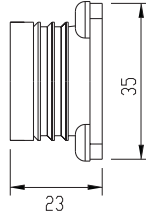

Shafts

6 mm with face

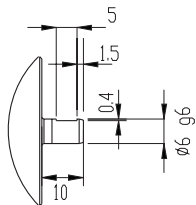

6 mm round

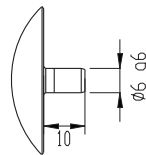

10 mm with face

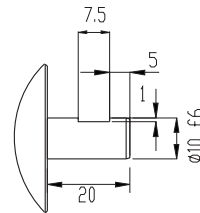

10 mm round

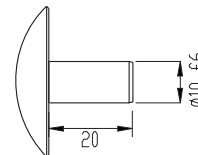

Various combinations/examples

RSI 503 51

10 mm with face, axial cable

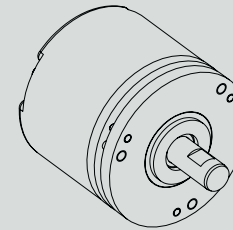

RSI 503 63

6 mm with face, radial PT

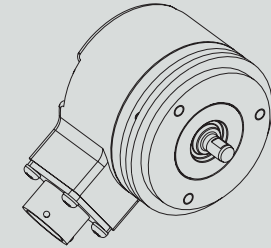

RSI 503 61

6 mm round, radial cable

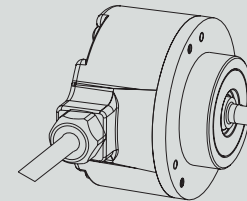

RSI 503 52

6 mm with face, radial cable

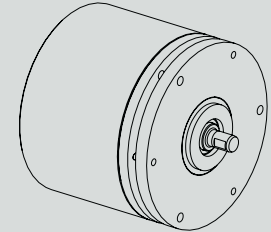

Ordering information Tick your choice

Type	RSI 503					
Flange	51, LL58	63, Synchro	61, Clamping	52, LL68		
Shaft	Ø6 round	Ø6 with face	Ø10 round	Ø10 with face		
Electronics ⁽¹⁾	Supply	5Vdc	9-30Vdc			
	Output	TTL	HTL	RS-422		
Connection	Cable	8 pin M12	12 pin EML	8 pin PT	6 pin MS	10 pin MS
Connecting direction	Axial ² /Radial	Axial ² /Radial ²	Axial ² /Radial ²	Axial/Radial ²	Axial ²	Axial/Radial ²
Line count	1..5000	5001..10 000				

⁽¹⁾ Possible combinations: 5Vdc/TTL, 9-30Vdc/HTL or 9-30Vdc/RS-422

⁽²⁾ Not available on flange option -52, LL68

Please, specify line count and cable length when ordering

Ordering example: RSI 503 63 Ø6ro 5Vdc 1024ppr TTL 8 pin PT Axial